

Programmable Room Thermostat



User Guide PBPRP & PBPRP RF

September 2010



CONTENTS

Overview	03
1 Battery access and user controls	04
1.1 Keyboard	04
1.2 Displays and LED	04
2 First time installation	04
2.1 Installing batteries	04
2.2 Time and date adjustment	05
3. Selecting a pre-set program	05
4. User Defined Programs	05
4.1 Creating a user defined program	06
5 Room temperature settings	07
5.1 Comfort temperature setting	07
5.2 Setback temperature setting	07
6 Operating menus	08
6.1 Automatic operation	08
6.2 Off function	08
6.3 Holiday function	08
6.4 Timer mode	08
6.5 Keyboard lock	08
7 External connections	08
7.1 Using the Wet Room Sensor	08
8 Pre-set programs	09
9 Technical details	11
10 Fault diagnostics	11
11 Installer Menus	12

OVERVIEW

The Polypipe range of Programmable Room Thermostats (PBPRP & PBPRP RF) provides time and temperature control for a space of up to 40m².

The hardwired PBPRP, is compatible with the wet room sensor PB23020 and should be installed 1.2m above floor level and away from direct heat sources. Wiring details are provided in the additional documentation.

The PBPRP RF is supplied with an RF receiver unit. Details on registering the thermostat with the receiver unit are provided in the additional documentation.

This user guide provides user settings and programming details. These, and the advanced settings, can also be downloaded in A4 format from www.ufch.com

Please Read Before Programming Your Thermostat

Temperature settings

The Programmable Room Thermostat operates at 2 different temperatures:

Comfort - When the space is occupied - the desired temperature

Setback - When the space is unoccupied - the temperature the room will not fall below

This is to assist the response time of the heating system.

For solid floor systems it is recommended that the Setback temperature is set no more than 4°C lower than the Comfort temperature. You may find that other systems can be set with a higher differential.

Time Settings

The room thermostats are preset with a function called Optimum Start (ITCS in the menu function). This means that you do not need to adjust each room for the warm up time from Setback to Comfort. The On Time in the pre-set programs, or the start time as defined by users in the User Defined programs, the time by which the room will be at the Comfort temperature by, not the time the heating will start to operate.

Each thermostat will learn the warm up time of each room, start the heating at a time to achieve Comfort by the time required, and self adjust for changes in outside temperature.

When this function is operating, i.e. the thermostat is heating prior to the actual time setting, the  symbol will blink.

This function can be de-activated in the Installer Menu (see page 9).

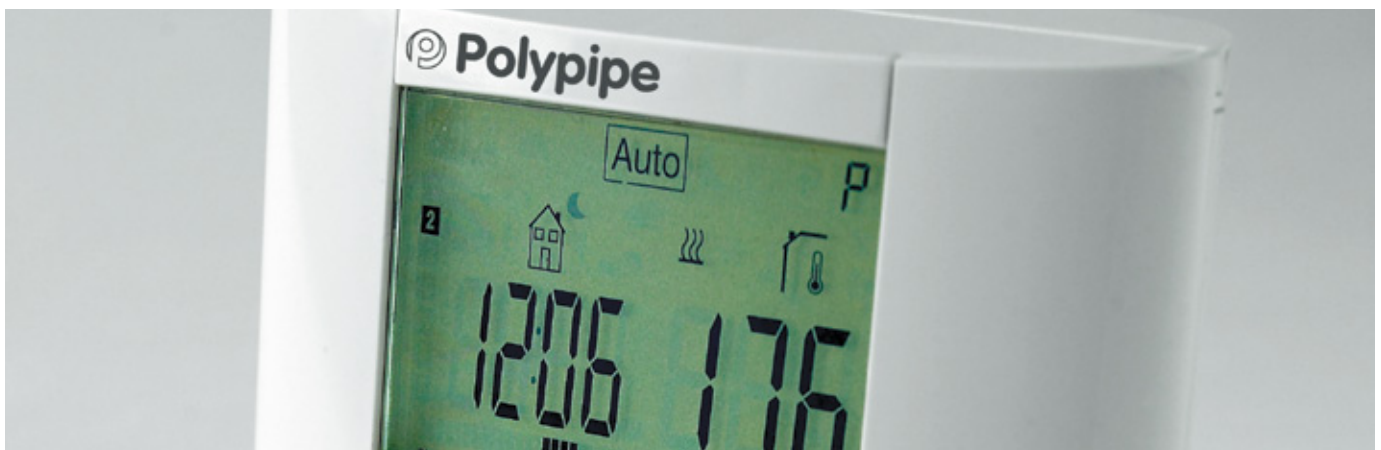

1. Battery Access & User Controls



1.1 Keyboard

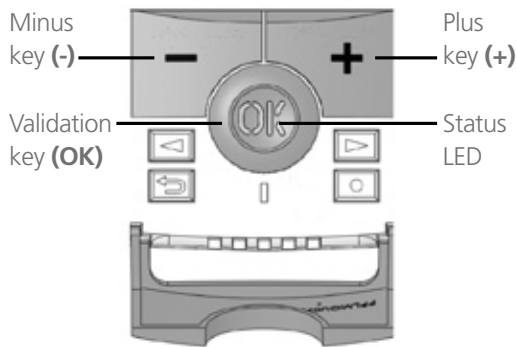

- Navigation key left (◀)
- Navigation key right (▶)
- Escape key (↵)
- Program key (●)

1.2 Display & LED



Red on: Heating demand
 Green flash: Attention
 Red flash: Error (batteries, sensor...)

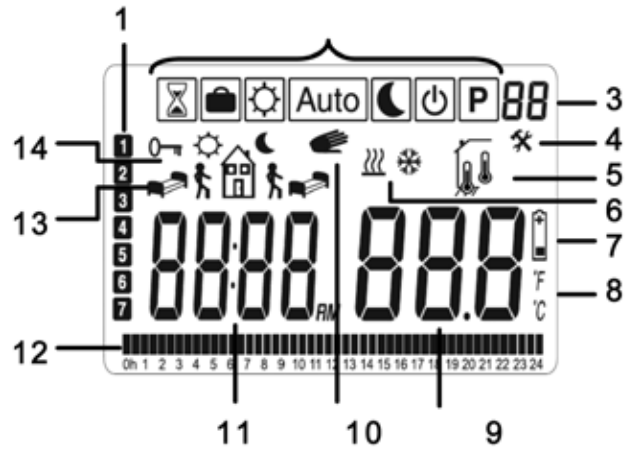

- 1 Current day of the week: 1 = Monday
- 2 Operating menu (active mode is framed)
- 3 Program number or parameter
- 4 Installer menu
- 5 Type of sensor used and temperature displayed
- 6 Heating demand indication
- 7 Low batteries indicator
- 8 °C or °F indicator
- 9 Setting or measured temperature
- 10 Temporary override activated, or "ITCS" function if blinking
- 11 Time
- 12 Program of the current day (the current time bare/blink)
- 13 Pictogram for programming
- 14 Key lock indicator

2. First Time Installation

This section will guide you to starting your thermostat for the first time.

2.1 Installing Batteries

- Open the two side covers and insert the 2 x AAA alkaline batteries supplied (or remove the small protection sticker if the batteries are already installed in the compartment).
- Close the two side covers
- Your thermostat will ask you to set the time
- **Note:** The time and date setting can be set at any time by pressing the (●) program key

2.2 Time and Date Adjustment

The digits to be adjusted will blink, and are adjusted with the keys (-) and (+). Once the adjustment is made, validate it with the (OK) key.

The thermostat will jump automatically to the next value.

Note: At each time you can return to the previous value by pressing the escape key (↵)

Progress of the adjustments:

Time and day:

Hours setting

Minutes setting

Day of week setting (1 = Monday)

Date:

Day setting

Month setting

Year setting

The message "Save" with the blinking green LED will be displayed, press (OK) to finish and save.

You can always reach the time and date adjustments, by pressing and maintaining the edition (●) key during 2 seconds in normal operating modes.

3. Selecting a Preset Program P1 to P9

There are 9 preset programs P1 – P9

The thermostat will default to P1 (see programs pages 9 to 11)

To select a preset program use the navigation keys to move the cursor from **Auto** to **P**

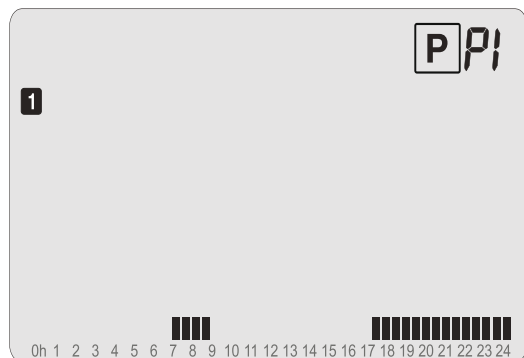

Press **OK** to make the P1/P9 adjustable

Use the (-) or (+) keys to choose **P1** to **P9**, or **U1** to **U4** (User Defined Programs)

Select and validate with (OK) to return to **Auto**

4. User Defined Programs U1 to U4

Pictograms to help programming will be displayed on the screen during programming.

These are as follows:



First step of the day

What time do you need Comfort temperature from?

Temperature is set to Comfort until next setting.



Middle step of the day – leave

What time do you leave (not occupy the room) in the middle of the day?

Setback temperature is set at this time until next setting.



Middle step of the day – return

What time do you return (re-occupy the room) in the middle of the day?

Comfort temperature is re-established until next setting.



Last step of the day

What time do you need the Comfort temperature until?

Setback temperature is re-established until the following morning.

If, for example at a weekend, the middle steps (leaving and returning) are not relevant, use the navigation keys to toggle and eliminate the mid sections. e.g:

Monday to Friday

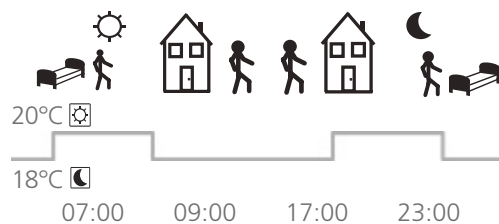

Saturday & Sunday



4.1 Creating User Defined Programs

Use the navigation keys to move from **Auto** to **P**. Press **(OK)** to make **P1/P9** adjustable.

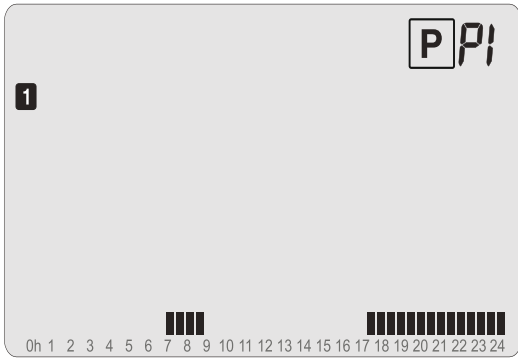

Use the **(-)** or **(+)** keys to choose **P1** to **P9**, or **U1** to **U4**

Select from **U1** to **U4** as this allows each thermostat to store up to 4 user defined programs in its memory.

With **U1** to **U4** blinking press the Program Key **(●)** to access the program settings.

- The program creation will always start with the day 1 (Monday).

Once you have pressed the **(●)** key, the following display will appear:

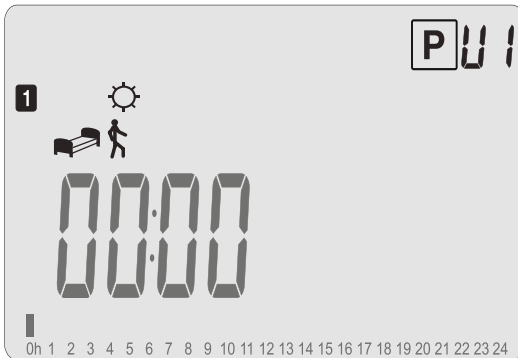

Adjust the hour of the first step of the program with **(-)** or **(+)**.

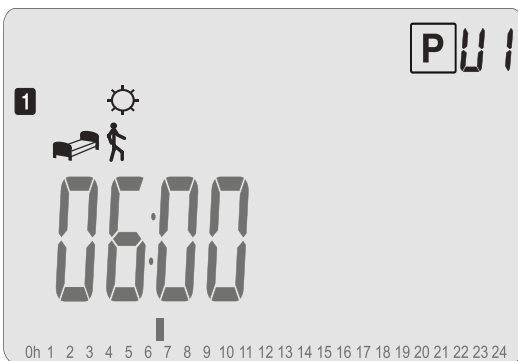

Press **(OK)** to validate and jump to the following step.

The pictogram will blink meaning that you can toggle between:



Choose and, press **(OK)** to validate.

Adjust the minutes of this step with **(-)** or **(+)**.

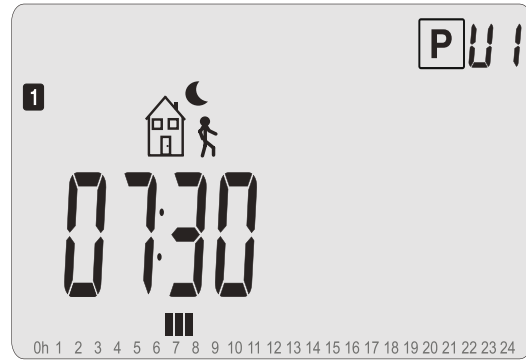

Press **(OK)** to validate and move to the next step.

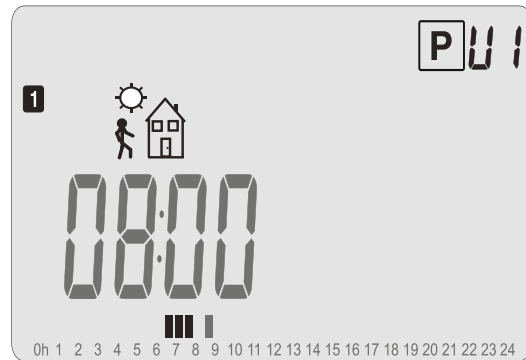

If you selected the  option you will automatically be required to select the return time with **(-)** or **(+)**. 

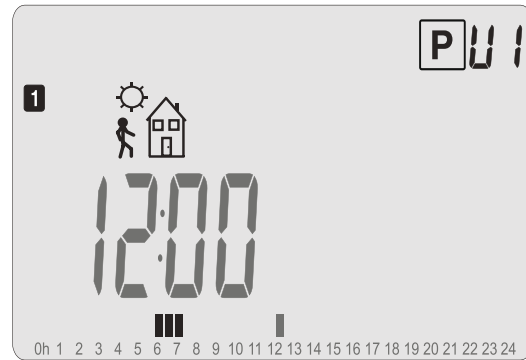

Select the return time, press **(OK)** and move to the next step.

The pictogram will blink again meaning that you can toggle between:



Should you wish to have a second “leave and return” during the day, use the navigation keys to select and press **(OK)** to validate. Adjust the hour of this step with **(-)** or **(+)**.

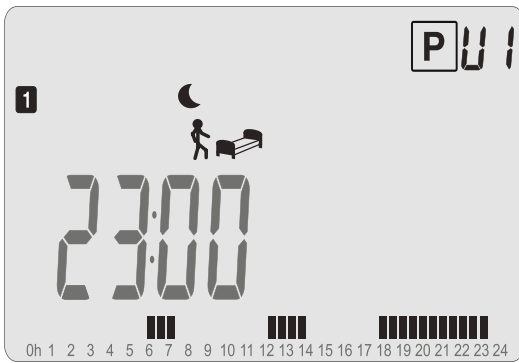

Press **(OK)** to validate and jump to finish the program setting of day 1 (Monday). The following screen with the blinking green LED will be displayed.



Press **(OK)** to save your program and return to the main screen (in **AUTO** mode).

Press the escape key (**↩**) to erase and come back to the beginning of the program mode.

You can now choose to copy the program just created to subsequent days.

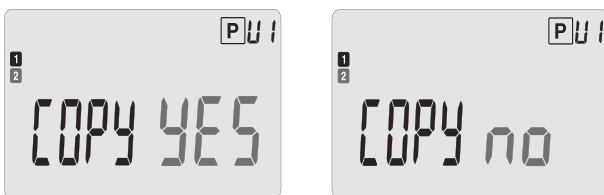

Change the choice “**YES**” or “**no**” with **(-)** or **(+)** and validate your choice with **(OK)**.

- If you select “**no**”, you will be invited to create a program for Tuesday (repeat the previous steps).

- If you select “**YES**”, you will have the option to copy the program from Tuesday to Wednesday, etc, up to the last day of the week (Sunday).

Press **(OK)** on the last day to “**SAVE**” your program.

5. Room Temperature Settings

In order to set room temperatures to work with the program you have selected or created you will need to access the mode menu.

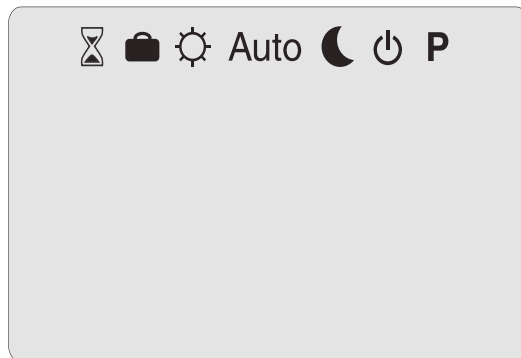

Use the navigation keys (**◀**) or (**▶**) to move the frame cursor over the required mode and **(OK)** to confirm your choice.

5.1 Comfort Temperature Setting

With the cursor over the Comfort setting  select and use the **(-)** or **(+)** keys to choose the Comfort temperature for the room. Validate with **(OK)**.

In the **Auto** mode this will be the temperature set for when the room is occupied only.

If the cursor remains positioned over  the room will permanently be set at the Comfort temperature.

5.2 Setback Temperature Setting

With the cursor over the Setback setting  select and use the **(-)** or **(+)** keys to choose the Setback temperature for the room. Validate with **(OK)**.

In the **Auto** mode this will be the temperature set for when the room is unoccupied.

If the cursor remains positioned over  the room will permanently be set at Setback temperature.

6. Operating Menus

6.1 Automatic Mode

In this mode the thermostat will follow the chosen program (Built-in or User defined) according to the time and the Comfort and Setback temperature settings.

You can easily override the current temperature of the program by pressing on the (-) and (+) in Auto mode at any time.

The current setting will blink to show you that you can change it. A small hand  will be display to show you have overridden Auto function, however Auto timings will return at the next time change.

6.2 Off Mode

Use this mode if you wish to turn off your thermostat.

Frost protection is automatically provided and a minimum temperature of 7.0°C will be maintained.

(This temperature can be changed, contact your installer or check advanced menu).

6.3 Holiday Mode

The Holiday mode allows you to adjust the temperature for a period of days:

The display will show "no", press (OK).

- Adjust the duration in day "d" with (-) or (+), press (OK) to validate (adjustable 1 to 99 days).
- Adjust the temperature setting (default value 10°C) with (-) or (+), press (OK) to start the function.

The  icon will blink and the number of days remaining is displayed until the end of the period.

If you want to stop the holiday function before the end of the duration adjust the day period on "no".

6.4 Timer Mode

The Timer mode allows you to adjust the temperature and the duration for a particular time.

This function can be used should you need to override the set program for a short time.

Adjust the duration in hours "H" if below 24H, then in days "d" with (-) or (+), press (OK) to validate (adjustable 1 hour to 99 days).

Adjust the setting temperature with (-) or (+), press (OK) to start the function (default value 22°C).

The  logo will be blink and the number of hours/ days left is displayed until the end of the period.

If you want to stop the timer function before the end of the duration adjust the period on "no".

6.5 Keyboard Lock Function

Use this function to prevent changes to the settings:

- To activate the key lock function, first press maintain the escape key (↵) and then press simultaneously on the edition key (●).
- The "🔒" icon will now be displayed on the screen.
- Repeat with the same procedure to unlock the keyboard.

7. External Connections

If accessories (wet room sensor) are installed on your thermostat, you can see all values by pressing the escape key (↵) (scroll function).

7.1 Settings for using the Wet Room Sensor

Note: The thermostat has hidden menus for calibration etc. These are described in the full version of this document on the Polypipe website www.ufch.com

The connection of the wet room sensor allows adjacent wet rooms to be controlled from a thermostat outside the room. However this sensor can also be used as a floor sensor to control floor surface temperatures where sensitive floor coverings are installed.

In the settings menu the sensor(s) are referred to as follows:

- Air** = The room thermostat
- Flr** = External sensor used as a floor sensor
- Ext** = External Sensor used as air sensor
- FL.1** = Both sensors used. Air temp with floor regulation

To access the Menu to set this, hold the escape key (↵) for 10 seconds.

You will then access the hidden installer menu.

Starting with menu 21, use the navigation keys to reach menu 23 REGU Air.

Press (OK) to toggle between the options with the (-) and (+) keys and verify with (OK).

If you choose FLR or FL.1, use the navigation keys to reach Menu 26 (FL:Lo) Floor Low limit can be set. Then Menu 27 (FL:Hi) Floor High limit can be set.

Continue to menu 35 (END) and (OK) to exit the settings Menu.

8. Pre-set Programs (1-4)

P1 Morning, Evening & Weekend

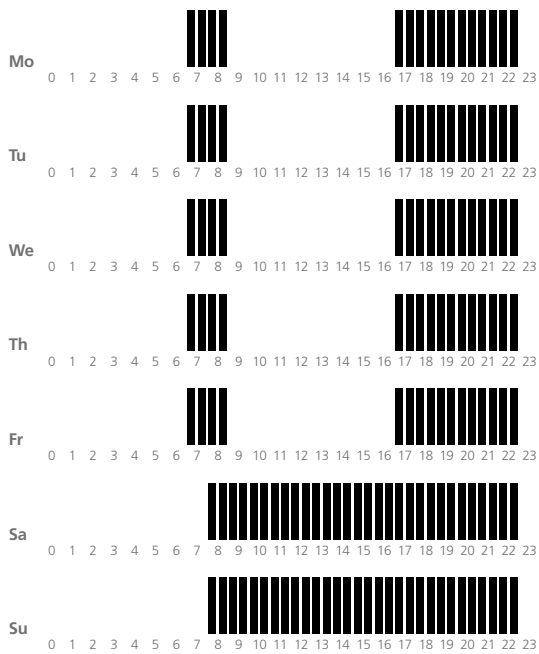

P2 Morning, Midday, Evening & Weekend

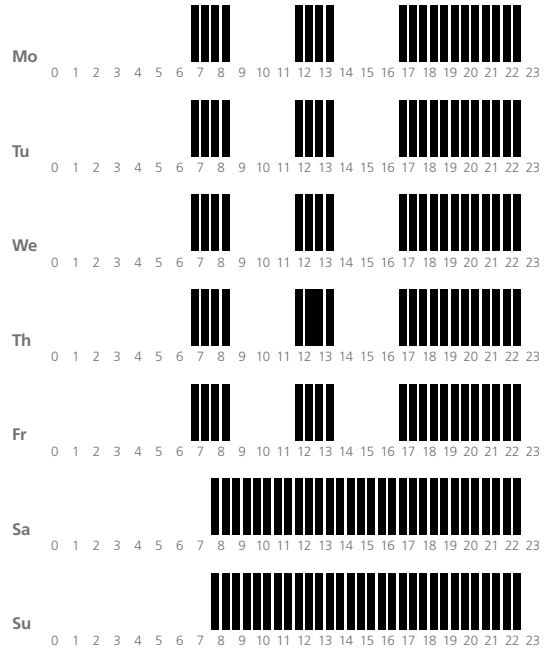

P3 Day & Weekend

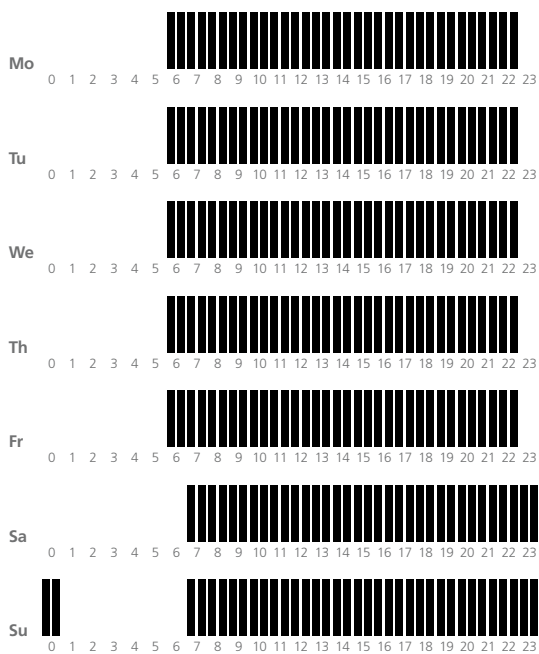

P4 Evening & Weekend

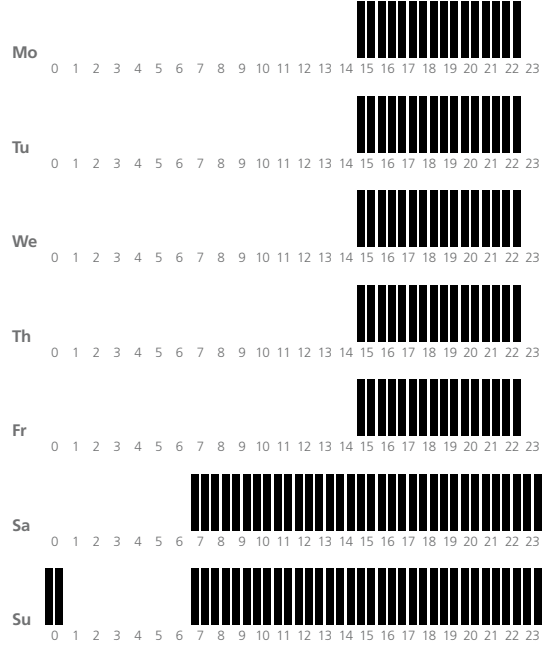

8. Pre-set Programs (5-8)

P5 Morning, Evening (Bathroom)

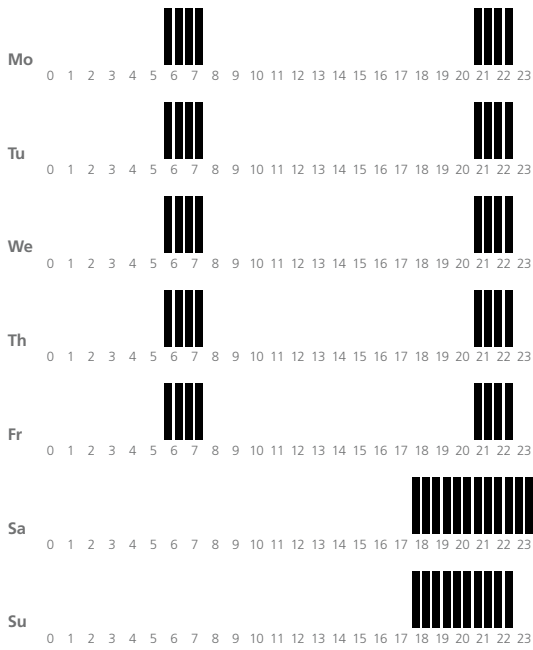

P6 Morning, Afternoon & Weekend

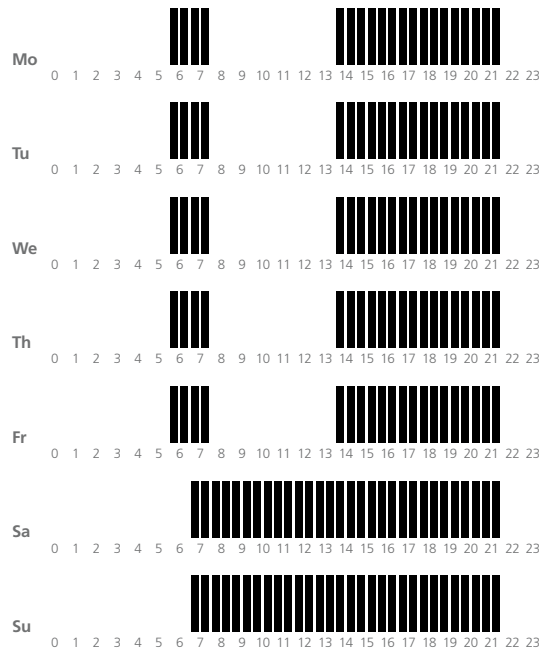

P7 7H – 19H (Office) P7 7H – 19H (Office)

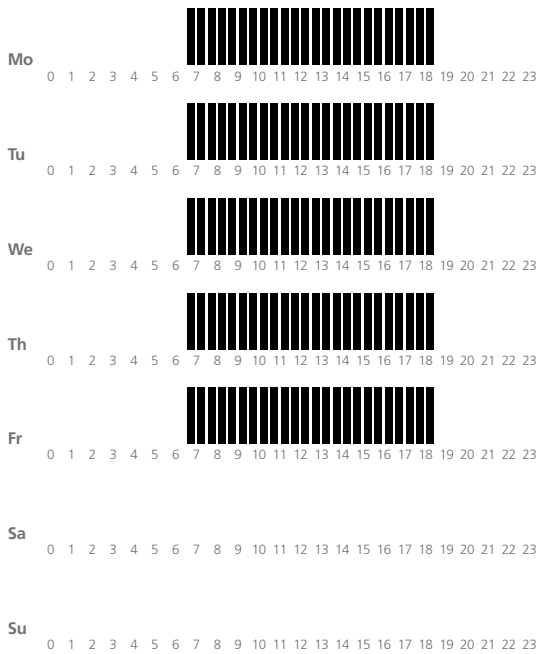

P8 8H – 19H & Saturday (Shop)

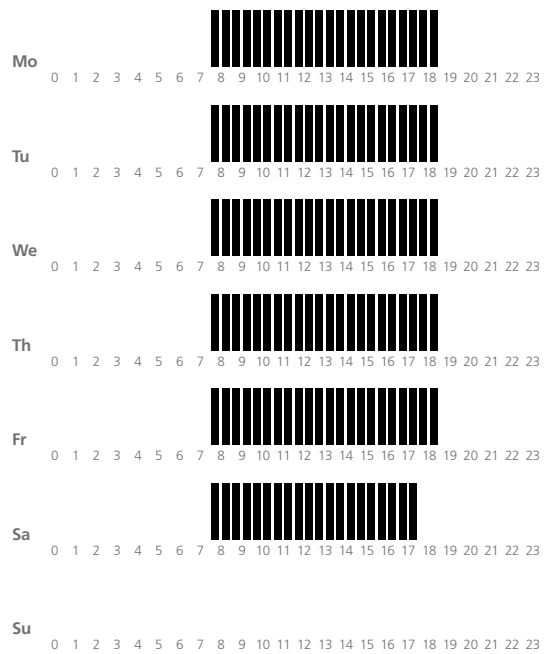

8. Pre-set Programs (9)

P9 Weekend (second house)

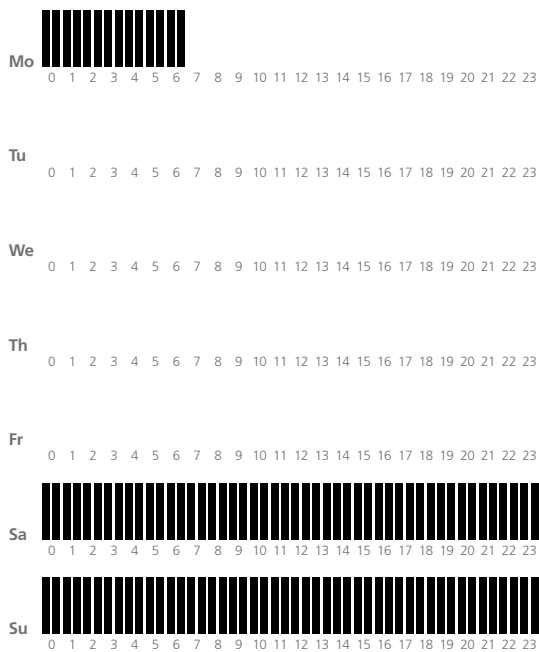

9. Technical details

Measured Temperature Precision:	0.1°C
Environmental Operating Temperature: Shipping and Storage Temperature:	0°C - 40°C -10°C to +50°C
Setting Temperature Range Comfort, Reduced: Holiday (Antifreeze): 10°C (adjustable): Timer:	5°C to 35°C by 0.5°C step 7°C 0.5°C to 20°C 5°C to 35°C
Regulation Characteristics:	Hysteresis of 0.5°C
Electrical Protection:	Class II - IP30
Power Supply: Alkaline Operating Life:	2 AAA LR03 1.5V 2 Years
Output:	2 Points Contact (Free Contact) Relay 5 Amps 250Vac
Optional External Sensor:	10k ohms at 25°C

10. Fault Diagnostics

My thermostat doesn't start	
Battery Problem	<ul style="list-style-type: none"> - Check if the protection sticker on the batteries is removed. - Check the orientation of the batteries. - Check the charge of the batteries.
My thermostat LED, blinks in red	
Problem on Sensors	<ul style="list-style-type: none"> The logo blinks (ambient sensor) - Contact your installer. The logo blinks (floor sensor). <ul style="list-style-type: none"> - Check the connection of the sensor. - Disconnect the sensor, and check it with an ohmmeter (the value must be around 10kohms).
Battery level is low	<ul style="list-style-type: none"> The logo blinks (batteries) - Replace the batteries.
My thermostat seems work correctly but the temperature in the room was never in accordance with the program	
Program	<ul style="list-style-type: none"> - Check the clock. - Check the difference between Comfort and Setback temperature is not too high? - Contact your installer, to check and adjust the calibration.

11. Installer Menus

There are 2 Installer Menus which can be accessed by pressing and holding the either :

Programme key (●) Programmes 1 to 12

or the escape key (↵) programmes 21 to 33

Installer Programmes 1 to 12

N°	Default value & other possibilities
01	Deg: Type of degrees displayed °C Celsius °F Fahrenheit
02	__:__ Selection of the clock 24H (24:00) 12H (12:00 AM /PM)
03	DST Automatic Daylight Summetime YES or NO
04	AirS: Instantaneous value of ambient sensor
05	Airc: Calibration of the internal probe The calibration can done after 1 working day with the same setting temperature in accordance with the following description: Put a thermometer in the room at 1.5M distance from the floor (like the thermostat) and check the real temperature in the room after 1 hour. When you enter on the calibration parameter "no" is displayed on the right to indicate no calibration has made. To enter the value read on the thermometer, use the (-) or (+) keys to enter the real value. Once, press (OK) to confirm. The message "Yes" should be displayed, the value will be stored in the internal memory. If you need to erase a calibration press on the escape key (↵). The old value will be erased and the message "no" will be displayed. Note: Only the heating element managed by the thermostat must be run during the complete step of the calibration.
06	EXTS – Instantaneous value of floor sensor
08	HG – Frost protection temperature 10deg C
09	ITCS: The Intelligent Temperature Control System or Optimun start programme will activate your system in advance to assure the desired temperature at the hour programmed
08	Clr ALL: Factory setting All parameters (Time, program...) will be reloaded with default setting values. Note Ensure you that you have all necessary elements to re-start before use this function.
09	Hyst: Hysteresis value 0.5°C or 1°C
10	Software version Vers __. __
11	End: Exit the Installers menu Press (OK) key to exit installater menu and return to normal operation.

Installer menus 21 to 33

N°	Default value & other possibilities
21	out NC/ NO - Type of actuator used ,set as normally closed (NC)
22	PUMP – YES/NO Pump exercise programme every 12 hrs
23-25	Settings for External sensor as previously described
26	Type HYS/ rEG – Type of regulation , hysteresis / proportional band
27	HYS St0.05 /1.1 Hysteresis band gap
28	tON 02 = relay ON anti short cycle in minutes
29	tOFF 02 = relay OFF anti short cycle in minutes
31	CP 0.00 = advanced parameter if internal sensor id heated by a heating element , compensation value in deg c at100% power
32	Clr EEP +hold OK = will reset non volatile memory programs to factory
33	End + OK to exit the Installer Menu

User Guide PBPRP & PBPRP RF Programmable Room Thermostat



Polypipe Building Products

Broomhouse Lane
Edlington
Doncaster DN12 1ES
Tel: 01709 770 000
Fax: 01709 770 001

2410 London Road
Mount Vernon
Glasgow G32 8XZ
Tel: 0141 778 8822
Fax: 0141 778 2703

Dromore Road
Lurgan, Craigavon
Co. Armagh BT66 7HL
Tel: 028 38 881270
Fax: 028 38 882344

www.polypipe.com

Underfloor heating systems trade website: www.ufch.com

Underfloor heating systems consumer website: www.freeyourwalls.com